

## 6. USING THE EXPRESS DISCONNECT™

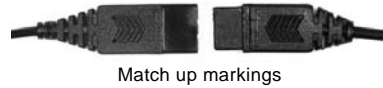

To disconnect the headset from the lower cord, firmly grasp both sides of the Express Disconnect (avoid pulling on the cord) and pull them apart.

To reconnect the headset to the lower cord again, take note of the markings on either side of the connectors. Match up the markings and push the two sides of the connector firmly together again.

## FREQUENTLY ASKED QUESTIONS

### Why do people have trouble hearing me?

- Be sure the word TALK or a painted dot on the microphone is facing your mouth (look under the microphone cushion). Be sure the microphone is positioned correctly at the corner of the mouth, about a finger's width away from your face just below your bottom lip.
- Check that connections are in the proper places and that the AC Adapter is pushed firmly into the amplifier.
- Make sure the microphone mute switch is in the active/on  position.
- Increase microphone volume. Do not adjust microphone volume until you are certain that the microphone is positioned correctly. Failure to do this may result in reduction of the noise canceling properties of the microphone.
- Check compatibility settings.

### Why do I have trouble hearing people?

- Check that connections are in the proper places and that the AC Adapter is pushed firmly into the amplifier.
- Increase receive volume.
- Check compatibility settings.

### I hear a hum or a buzz when I am on a call.

- Check that the AC Adapter is pushed firmly into the amplifier.
- If you have a computer nearby, move the amplifier further away from the monitor.
- If the AC adapter is plugged into a power bar, try plugging the AC adapter directly into the wall electrical outlet.

## VXI LIMITED WARRANTY

- VXI warrants that your PE100 headset system will be free from defects in material and workmanship for two years from the date of purchase. If, during the first two years from the date of purchase, your PE100 headset fails to work due to a defect in material or workmanship, VXI will repair or replace the product, at its election, free of charge. Without proof of purchase, the warranty period begins on the date of manufacture.
- The foregoing limited warranty does not cover equipment failure attributable to accident, improper operation, misuse, abuse, or any cause other than defects in the materials or workmanship of VXI's products.
- VXI's obligations under this warranty are limited to repair or replacement (at our option) of any defective part returned to VXI, freight prepaid. Returned products require a Return Authorization that may be obtained by calling customer service at 1-800-742-8588.
- THIS LIMITED WARRANTY IS IN LIEU OF ALL OTHER WARRANTIES, EXPRESS OR IMPLIED, INCLUDING THE IMPLIED WARRANTIES OF MERCHANTABILITY AND FITNESS FOR A PARTICULAR PURPOSE. Some jurisdictions do not permit the exclusion of implied warranties and the foregoing exclusions may not apply to you.
- In no event shall VXI be responsible for any other damages whatsoever, including direct, indirect, special, incidental, consequential, or other damages for breach of this or any other warranty, express or implied.
- Products returned to VXI for in-warranty, freight prepaid and with proper Return Authorization, will be return shipped to the customer at VXI's expense.

For customer service, please call:  
VXI Corporation  
1-800-742-8588 or 603-742-2888  
Technical support is available on our web site at: [www.vxiparrott.com](http://www.vxiparrott.com)

For customer assistance, please call VXI at 1-800-742-8588 or visit our website at [www.vxiparrott.com](http://www.vxiparrott.com).

# vxiparrott PE100

## Headset System for Corded Phone Systems

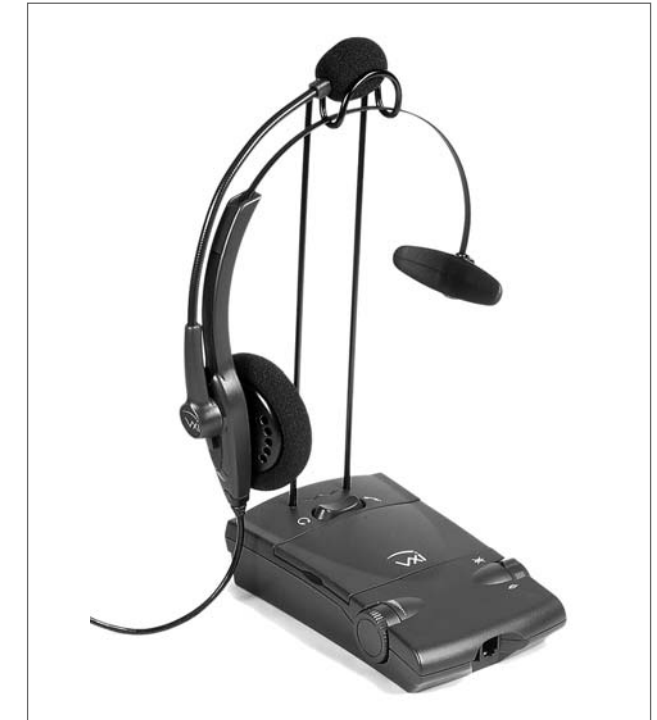

VXI CORPORATION  
One Front Street, Rollinsford, NH 03869  
603-742-2888 Toll free 1-800-742-8588  
e-mail: [info@vxiparrott.com](mailto:info@vxiparrott.com) website: [www.vxiparrott.com](http://www.vxiparrott.com)

## FEATURES & COMPONENTS

- Noise canceling microphone
- Adjustable headband
- T-Bar
- Receiver / ear cushion
- Headset holder (removable)
- Headset/handset switch
- Microphone mute switch
- Headset port
- Receive volume wheel
- Top door access to compatibility switches and microphone volume
- Rotating boom for left or right side microphone placement
- Flexible "gooseneck" microphone boom
- AC adapter
- Patch cord
- Coil cord

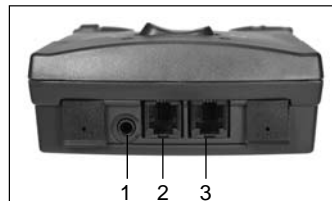
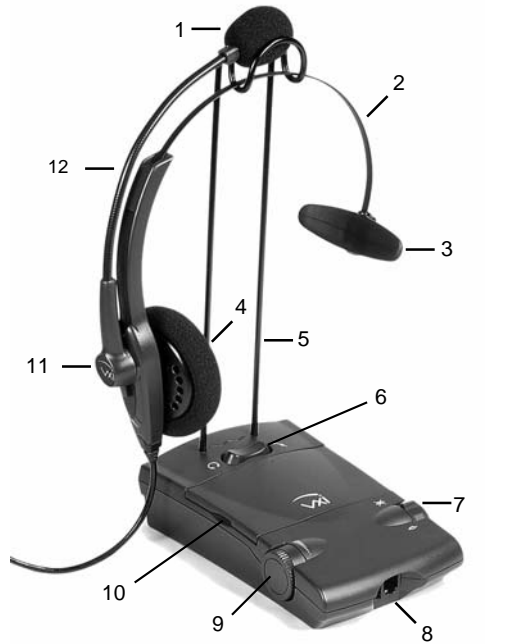

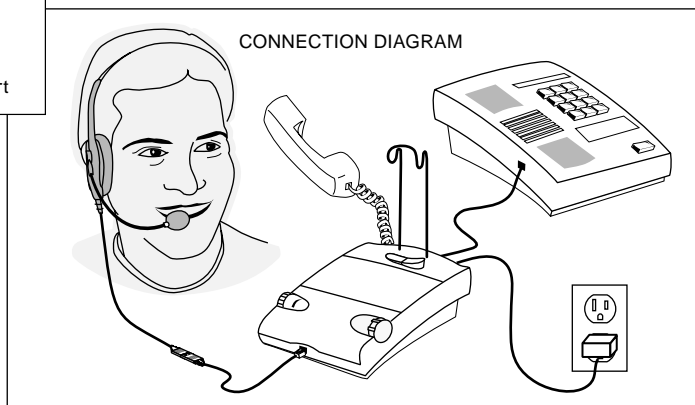
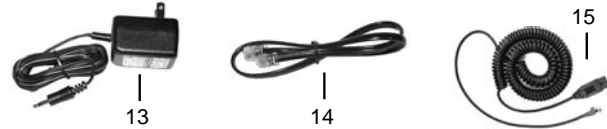

- AC adapter port
- Patch cord port
- Telephone handset port



Refer to icons printed on bottom label of amplifier.

### 1. INSTALLING YOUR AMPLIFIER

- Remove the coiled handset cord from your telephone and plug it into the jack marked  on the rear of the amplifier.
- Connect one end of the Patch Cord into the now empty handset jack on your telephone. Connect the other end of the Patch Cord into the jack marked  on the rear of the amplifier.
- Plug the AC Adapter into the jack marked  on the rear of the amplifier. Plug the AC Adapter into the wall electrical outlet.
- Insert red plug on Coil Cord into Headset Port on front of the amplifier and connect the other end of the Coil Cord to the Express Disconnect on the headset (see back page of this user guide for more information about using the Express Disconnect).

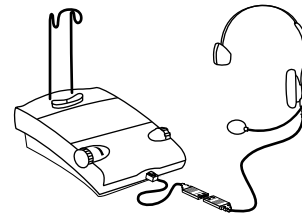
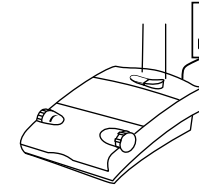
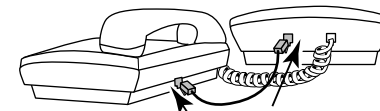

### 2. CHOOSE A SIDE FOR THE MICROPHONE.

Determine which side of your head you would prefer to locate the microphone. Swivel the microphone boom as shown.

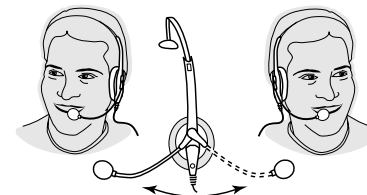

### 3. MICROPHONE ADJUSTMENT.

Position the microphone so it is located one finger-width from the corner of your mouth. The microphone has either the word TALK embossed on it or a painted dot printed on it (look under the cushion). This mark must face your mouth.

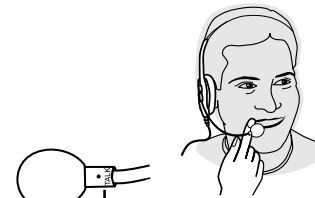

"TALK" or a dot

### 4. SETTING COMPATIBILITY

- Put on headset.
- Depress left side of headset/handset switch.
- Remove telephone handset from its cradle.
- Rotate Talk/Mute switch forward to activate microphone.
- Lift door and adjust in the following order:

A1 through A4  
B1 through B4

Choose setting with best dial tone and then close door.

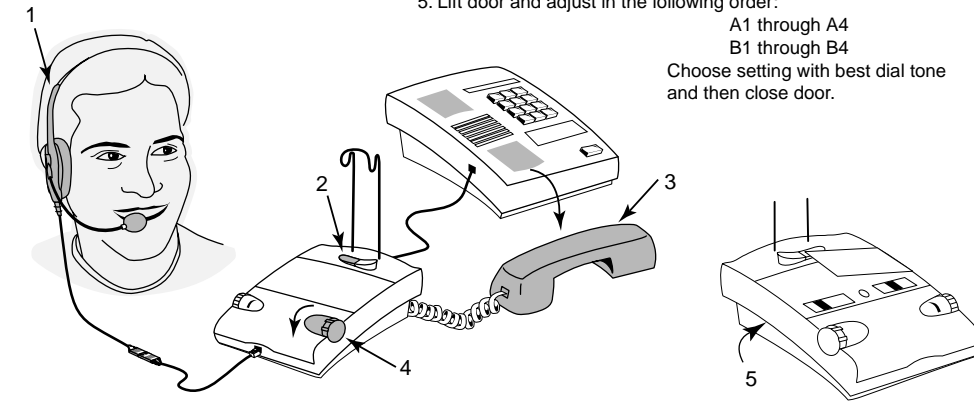

### 5. USING YOUR AMPLIFIER

	<p>To use headset, depress the left side of the headset/handset switch.</p>		<p>Remove the telephone handset from its cradle and make a call.</p>
	<p>Adjust the receive volume by rotating the volume control.</p>		<p>If necessary, adjust the microphone volume. Lift the top door of the amplifier. Gently rotate the center knob.</p>
	<p>Rotate the talk/mute switch forward to activate the microphone, and away from you to mute the microphone.</p>		<p>To use the telephone handset, depress the right side of the headset/handset switch.</p>